

AM5XT SIGNALING ADAPTOR MODELS 30-0033 AND 30-0033XT INSTRUCTION MANUAL

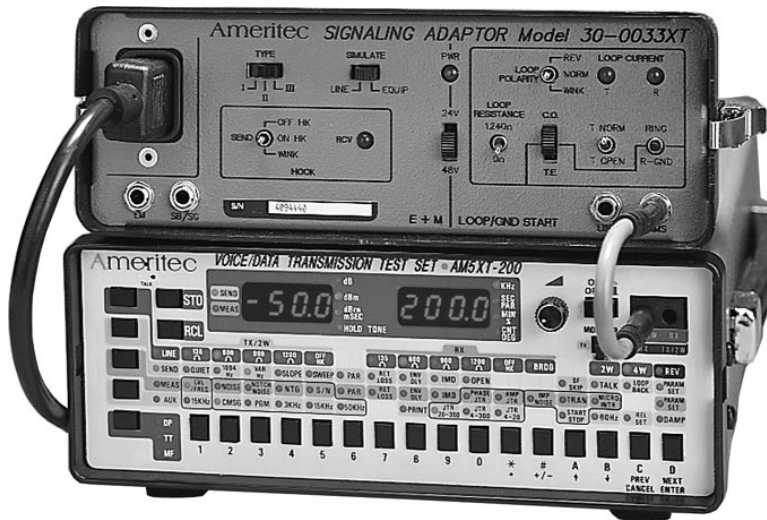

Ameritec

**AM5XT SIGNALING ADAPTOR
MODELS 30-0033 AND 30-0033XT
INSTRUCTION MANUAL**

August 1997

Technical Data Subject to
Change without Notice

Ameritec

760 Arrow Grand Circle
Covina, CA 91722 USA

TEL 626.915.5441

FAX 626.915.7181

www.ameritec.com

For extra copies of
this manual, order
P/N 18-0023

© 2000 Ameritec Corporation

RECORD OF REVISIONS

A	May 1989	Original Issue of 30-0033 unit
A1	July 1990	Revision of manual to include preliminary release of 30-0033XT unit
B	October 1990	Original Issue of 30-0033/30-0033XT
B1	March 1992	Warning notice for CO/TE switch added
B2	May 1992	Proper setting of Loop Resistance switch addendum added.
B3	February 1994	Minor revisions.
C	August 1997	Updated format. Incorporated all previous revisions.

Warning

Before connecting the Signaling Adaptor to a circuit which has battery voltage applied already (wet circuit), be sure that the C.O./TE switch is set to the TE position. Damage to Signaling Adaptor may result if the unit is set to C.O. position when it is connected to a wet circuit.

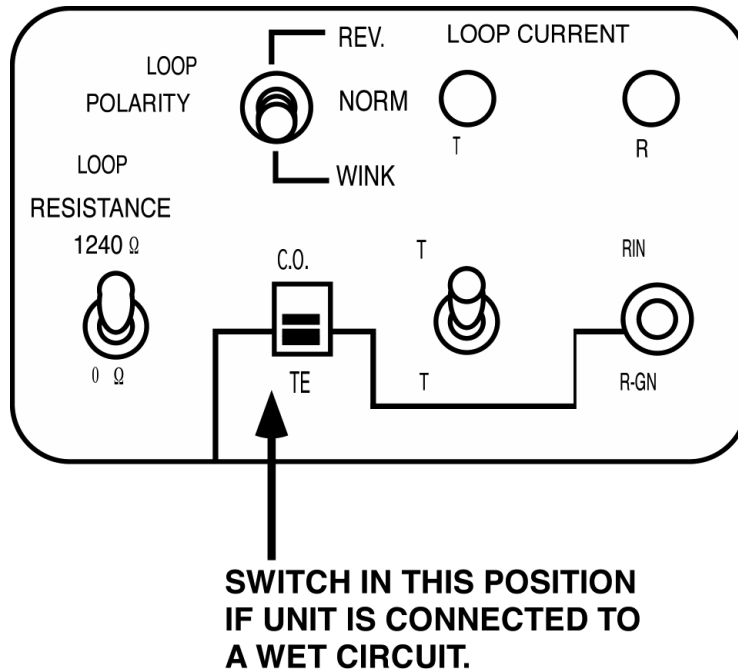

TABLE OF CONTENTS

1. GENERAL INFORMATION.....	1-1
1.1 Product Description	1-1
1.2 See Warning Notice at the Front of this Manual	1-1
1.3 The Front Panel.....	1-1
1.4 E&M Components	1-3
1.5 Ground Start, Loop Start and DID Components.....	1-4
1.6 Notation Methods	1-6
1.7 Technical Specifications.....	1-7
2. E&M APPLICATIONS	2-1
2.1 Set Appropriate Operating Conditions	2-1
2.2 To Receive a Call	2-3
2.3 To Originate a Call.....	2-4
3. GROUND START APPLICATIONS.....	3-1
3.1 Set Appropriate Operating Conditions	3-1
3.2 To Simulate a PBX	3-2
3.3 To Originate a call to the CO.....	3-3
3.4 To Terminate a call from the CO:.....	3-3
3.5 To Simulate a CO	3-3
3.5.1 To Terminate a call from the PBX:.....	3-4
3.5.2 To Originate a call towards the PBX:.....	3-4
4. LOOP START APPLICATIONS.....	4-1
4.1 Set Appropriate Operating Conditions	4-1
4.2 To Simulate a PBX	4-1
4.3 To Simulate a CO	4-2
4.3.1 To Terminate a call from the PBX or Phone:.....	4-2
4.4 To Originate a call towards the PBX or Telephone (30-0033XT Only):	4-3
5. DIRECT INWARD DIAL (DID) APPLICATIONS	5-1
5.1 Set Appropriate Operating Conditions	5-1
5.2 To Simulate a PBX DID Operation:.....	5-1
5.3 To Simulate a CO DID Operation:.....	5-2
6. WARRANTY AND SERVICE POLICY	6-1
6.1 Service Policy	6-1
6.2 Calibration Policy.....	6-1
6.3 Return of Unit.....	6-2

FIGURES AND TABLES

Table 2-1. The "TYPE" and "SIMULATE" Switches for E&M Circuits 2-2
Figure 3-1. Switch and Pushbutton Functions in the "CO" and "TE" Modes..... 3-2

A. INTRODUCTION

The purpose of this document is to provide general information and detailed operating instructions for the Ameritec AM5XT 30-0033 and the 30-0033XT Signaling Adaptors. Included are step-by-step procedures for setting up and operating the unit on E&M, Ground Start, Loop Start and DID circuits.

The document is intended to be used with the Model AM5XT and AM5eXT Instruction Manual, Part Number 18-0022 and the Model AM5XT and AM5eXT Test Operating Procedures document, Part Number 18-0119. The Test Operating Procedures document is included in the Instruction Manual and can also be purchased separately.

Refer to the Test Operating Procedures document for detailed instructions for performing transmission impairment tests once the connection has been established with the 30-0033 or 30-0033XT Adaptor.

This document contains five sections. The first, General Information, provides an overview of the AM5XT 30-0033 and 30-0033XT Adaptors, the front panel components and technical specifications for each adaptor. All readers should review this section before using either version of the adaptor.

The second through fifth sections provide step-by-step procedures for setting up each unit and initiating or terminating calls on E&M, Ground Start, Loop Start and DID circuits respectively.

Note: The Model 30-0033 is no longer manufactured. Information is provided for reference only. This Signaling Adaptor is also useable with other TIMS units such as the AM5(e) Classic, AM-42(e), AM-44(e) and AM-48(e) Transmission Test Sets and similar units manufactured by other companies.

1. GENERAL INFORMATION

This section provides product description and information about the front panel of the Ameritec AM5XT 30-0033 and 30-0033XT Adaptors. Topics include the location and function of switches, LEDs and connectors used for controlling the unit and indicating its operational status.

1.1 Product Description

The AM5XT 30-0033 and 30-0033XT Signaling Adaptors are packaged within the cover (lid) of the AM5XT Voice/Data Transmission Test Set. These units provide for Loop Start, Ground Start, DID and Types I, II and III E&M signaling. Each unit is powered externally by connection to a 115VAC source and contains a selectable 24 or 48 volt battery supply for emulating CO operations.

1.2 See Warning Notice at the Front of this Manual

The 30-0033XT also contains a selection for 1240 ohm or 0 ohm loop resistance. The 30-0033 is fixed at 0 ohm loop resistance.

The Model 30-0033XT also has a Ring Generator, which is not included in the 30-0033.

1.3 The Front Panel

The front panel is separated into two halves. For this instruction manual, all illustrations will represent the XT version of the Signaling Adaptor. For reference, however, the front panel of the earlier Model 30-0033 is shown on the next page.

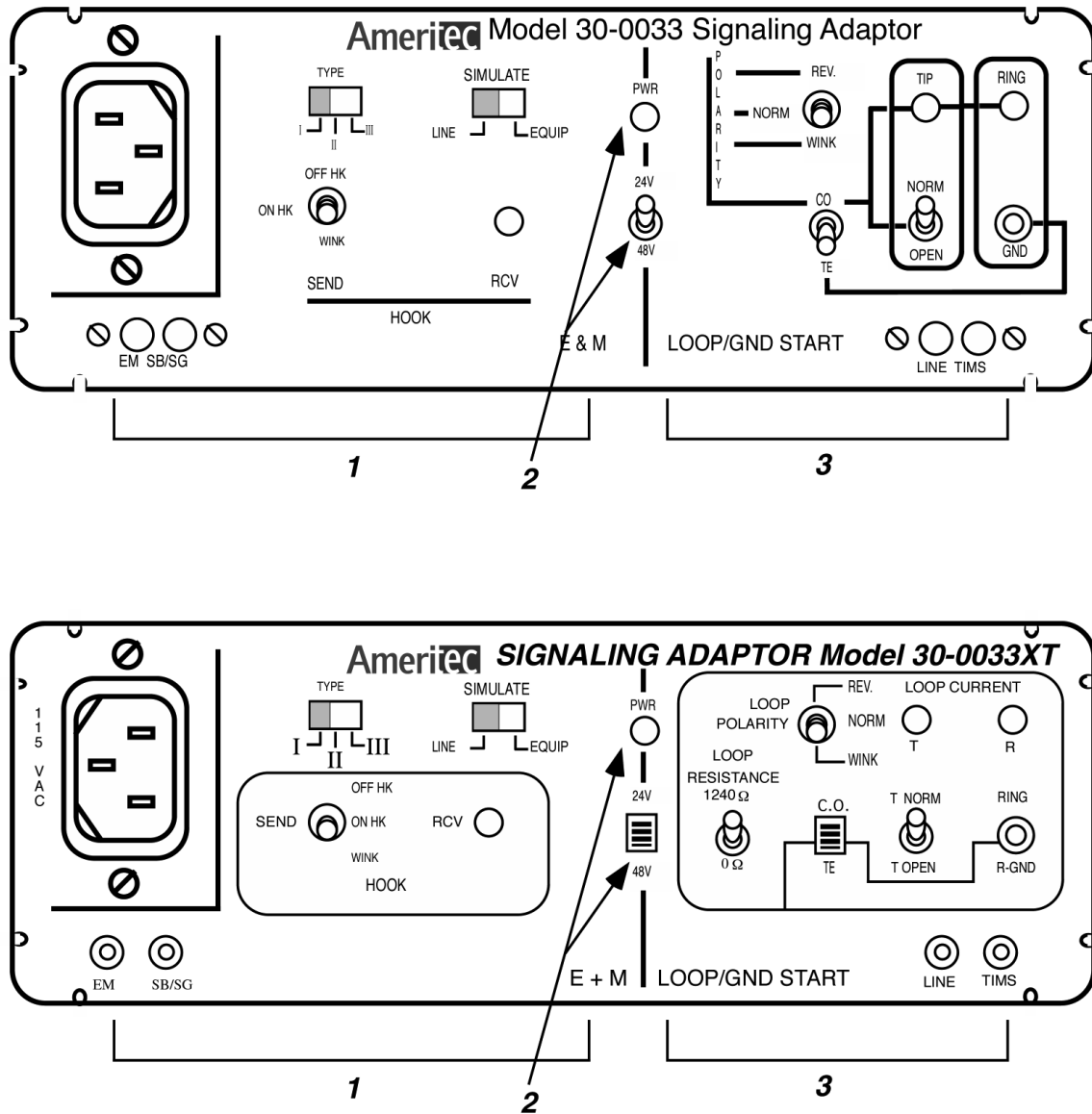

1. The left half is used for operation on E&M circuits.
2. The AC Power-On LED and 24/48 Volt switch divide the panel into halves. The Power LED and switch are used by the circuits on both halves. The Power LED lights when 115VAC is applied to the unit.
3. The right half is used for operation on Ground Start, Loop Start and DID circuits.

1.4 E&M Components

The following components are for use in E&M applications.

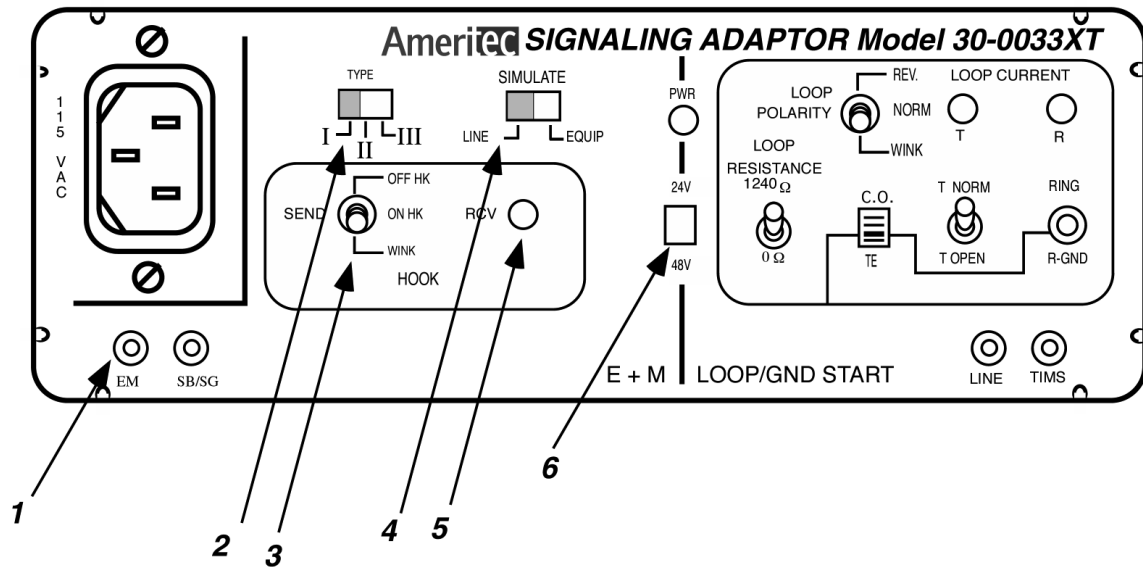

1. E&M and SB/SG bantam jacks are used for connection to the circuit under test. The T,R/T1,R1 leads are connected directly to the AM5XT.
2. The "TYPE" switch is used for selecting Type I, II or III E&M circuits.
3. The "SEND" three-position switch is used for placing the unit Off-Hook, On-Hook or sending a momentary to the other end.
4. The "SIMULATE" switch is placed in "LINE" if you are displacing the line and testing directly into the PBX or CO equipment or in "EQUIP" if you are connecting to the transmission facility.
5. The "RCV" LED lights to indicate a signal or a wink from the far end.
6. The "24/48 Volt" switch selects the voltage required/supplied by the E&M and SB/SG leads.

1.5 Ground Start, Loop Start and DID Components

The following components are for use in Ground Start, Loop Start or Direct Inward Dial (DID) applications.

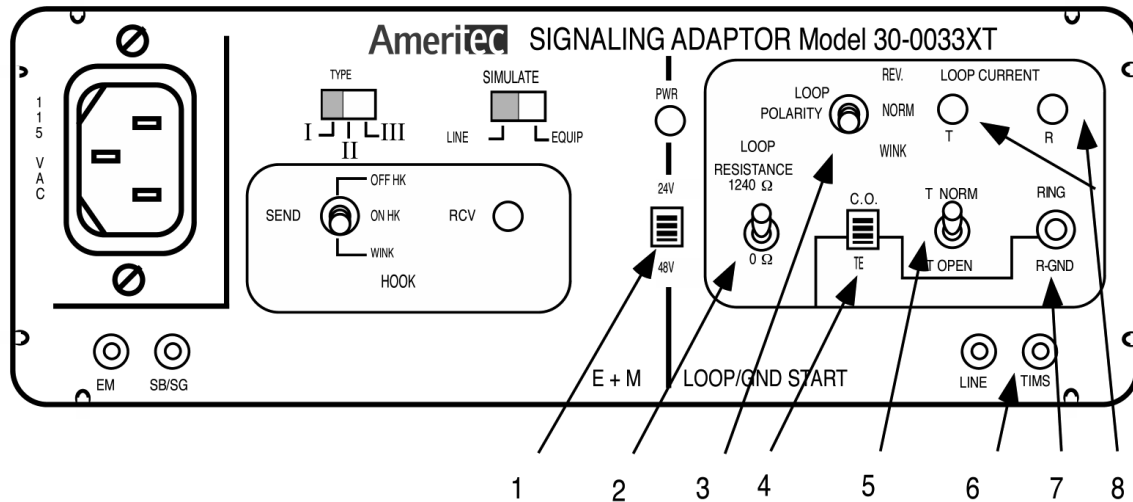

1. The "24/48 Volt" switch selects the voltage supplied to the line when the unit simulates a CO.
2. The "1240/0 ohm" switch selects the loop resistance of the line when the unit simulates a CO (30-0033XT only; The 30-0033 is fixed at no loop resistance).

Proper Setting of LOOP RESISTANCE Switch:

When testing a circuit that has a loop resistance of greater than 500 ohms, set the switch to 0 ohm. If the circuit has a loop resistance of 500 ohms or less, set the switch to 1240 ohm. If the LOOP RESISTANCE is set to the wrong loop resistance, the following conditions will occur:

- Setting the switch to 0 ohm when the existing loop has a resistance less than 500 ohms may result in high noise measurements on the AM5XT (approximately 35 to 40dBm).
- Setting the switch to 1240 ohm when the existing loop has a resistance greater than 500 ohms may prevent the LOOP CURRENT T and R LEDs (Item 8) from activating. (High loop resistance may limit the current flow necessary to activate the LEDs.)

Note: Due to manufacturing tolerances, a few units may begin to generate noise with a loop resistance greater than 500 ohms. Others may experience difficulty illuminating the LOOP CURRENT T and R LEDs with a loop resistance less than 500 ohms. If either of these symptoms occur, an intermediate 600 ohm pad between the circuit and the LINE jack should eliminate the problem.

3. The "POLARITY" three-position switch is used for reversing the polarity of the Tip and Ring lines or sending a momentary wink to the other end. The center position provides normal polarity.
4. The "CO"/"TE" switch is placed in the "CO" position when simulating a CO and in the "TE" position when simulating a PBX or phone.

WARNING: Before connecting the Signaling Adaptor to a circuit which has battery voltage applied already (wet circuit), be sure that the C.O./TE switch is set to the TE position. Damage to Signaling Adaptor may result if the unit is set to C.O. position when it is connected to a wet circuit.

- When in the "CO" position the following are active:
 - LOOP POLARITY switch
 - T-NORM/T-OPEN switch
 - 1240/0 ohm switch (30-0033XT)
 - RING pushbutton (30-0033XT)
 - LOOP CURRENT T ("Tip") and R ("Ring") LEDs
- When in the "TE" position, only the "R-GND" pushbutton is enabled.

Note: Lines on the panel silk-screening indicate that when the "CO/TE" switch is in the "CO" position, the "POLARITY" switch, "T-NORM"/"T-OPEN" switch and the "TIP" and "RING" LEDs are active.

5. The "T-NORM"/"T-OPEN" switch is placed in "T-NORM" to apply either 24 or 48 volts to the line when simulating a CO or in "T-OPEN" to place a ground start line in idle. The function of this switch is to open the tip lead. This switch is only active when the "CO"/"TE" switch is in the "CO" position.
6. LINE and TIMS bantam jacks are used for connection to the circuit under test and the AM5XT. These jacks are wired in parallel to allow the TIMS to bridge the line.
7. In the "TE" mode, the "R-GND" pushbutton is used to ground the ring side of the line for a Ground Start circuit. When in "CO" position, this switch applies a Ring voltage across Tip and Ring of the Line Jack (XT ONLY).
8. The "TIP" and "RING" LEDs light to indicate line activity when the "CO"/"TE" switch is in the "CO" position.

1.6 Notation Methods

The following notation methods are used for the operating procedures in Sections 2-5. Most procedures include an illustration of the front panel as shown below. The switches and LEDs are numbered in the same order in which they are used.

Below the illustration is the detailed sequence of steps required to perform the procedure.

Numbers indicate steps that are performed using the 30-0033XT front panel components as shown in the illustration.

Numbers within parentheses indicate steps that are performed on the AM5XT. Refer to the Model AM5XT and AM5eXT Instruction Manual (18-0022) or the Model AM5XT and AM5eXT Test Operating Procedures document for additional information if required. The Test Operating Procedures document (18-0119) is included in the Instruction Manual and can also be purchased separately.

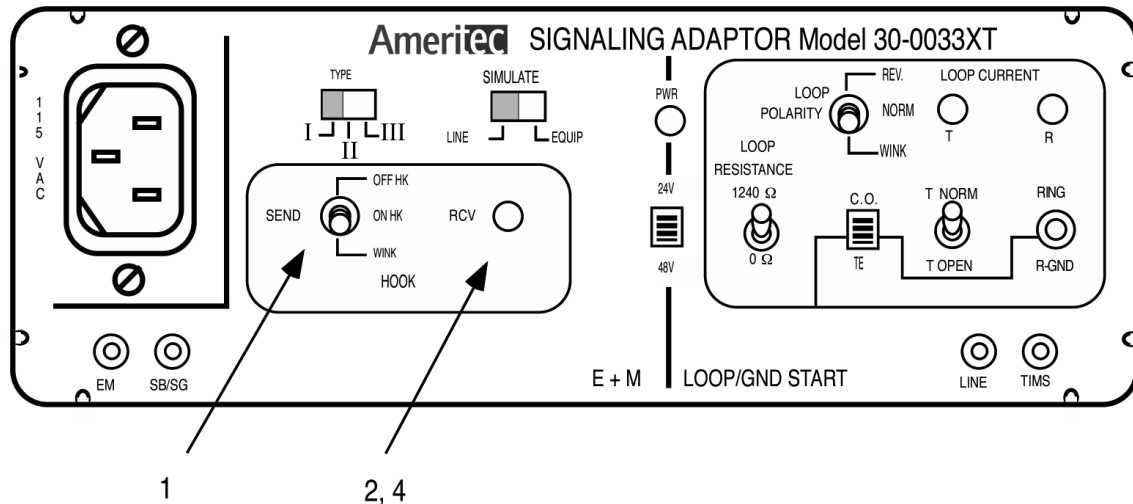

1. Position the "SEND" switch to "OFF HK".
2. Watch for the "RCV" LED to wink.
3. **AM5XT Only:** Use the AM5XT's Dialing Mode Enable Key to select either DTMF or MF dialing and dial the number.
4. If the called number provides "answer supervision", the "RCV" LED lights permanently when the line is ready for testing .

1.7 Technical Specifications

The following are the technical specifications for the Model 30-0033 and 30-0033XT AM5XT Signaling Adaptors:

- **POWER REQUIREMENTS:**
115VAC + 10%, 60Hz
- **LINE SUPPLY VOLTAGES:**
24 or 48 VDC \pm 5%, Switch Selectable Source Resistance:
30-0033 : 360 ohm (2 X 180 ohm)
30-0033XT : 400 ohm (2 X 200 ohm)
- **LOOP SELECTION:**
0 ohm/1240 ohm (XT ONLY)
- **EMULATION MODES:**
E&M (Types I, II and III)
Loop Start
Ground Start
DID
- **WINK DURATION:**
250ms typical (may be manually-held for longer periods)
- **RING GENERATOR (30-0033XT Only):**
Frequency = 20 Hz \pm 10% Square Wave
Output Level = 150 Vpp \pm 10% (3 ringer load, 0 ohm loop)
Ring Trip:
2.4k loop @ 24 Vdc
4.8k loop @ 48 Vdc
Ring Cadence: Operator Controlled
DC Bias: -24VDC or -48VDC

- **BANTAM CONNECTIONS:**
 - EM (E & M)
 - SB / SG
 - LINE (T,R)
 - TIMS (T,R)
- **LED INDICATORS FOR:**
 - Power Applied
 - E&M Receive Answer or Wink
 - Tip Current >30ma
 - Ring Current >30ma
 - (1200 ohm loop for 48V)
 - (440 ohm loop for 24V)
- **PHYSICAL SIZE:**
 - 8" L X 2 7/8" W X 2 1/4" H (Mounted in standard AM5XT lid)
 - Unit Weight: 1.5 lbs.
 - Shipping Weight: 3 lbs.
- **MISCELLANEOUS CHARACTERISTICS:**

Dialing is accomplished via the AM5XT, AM5eXT or similar separate TIMS. The 30-0033 and 30-0033XT are not compatible with dial pulse dialing on E&M lines and do not provide dial tone.

2. E&M APPLICATIONS

2.1 Set Appropriate Operating Conditions

- Connect the Model 30-0033(XT) to a 115VAC power source.
- Verify that the "PWR" LED in the center of the unit is lit.
- Set the "Type", "Simulate" and "24/48 Volt" switches and connect the circuit under test as directed below.
- The left side of the unit is used for operation on E&M circuits. Table 2-1 on the next page shows the internal circuitry presented to the unit connectors, based on the settings of the "TYPE" and "SIMULATE" switches.

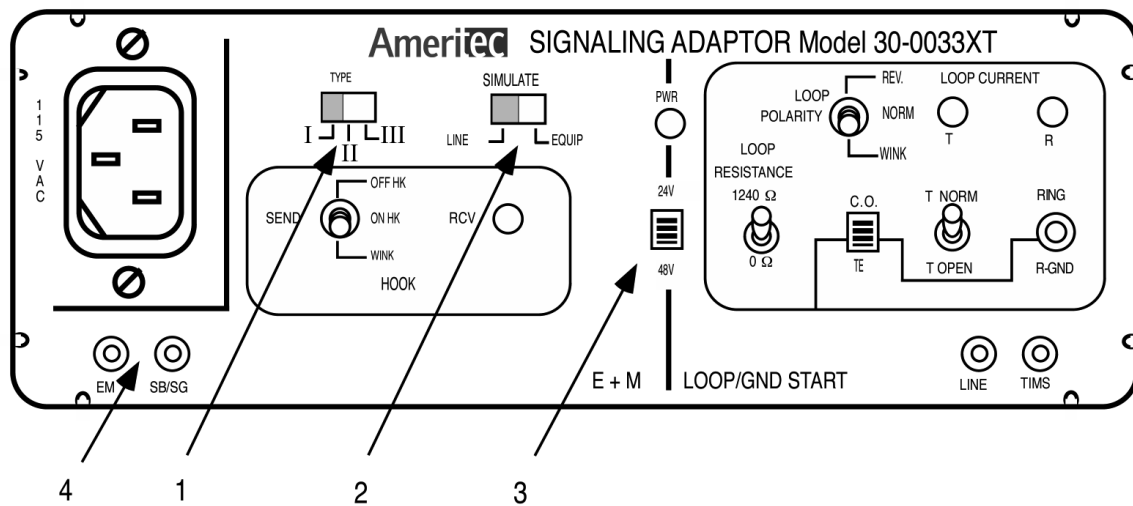

1. Position the "TYPE" switch to correspond to the E&M line under test — Type I, II or III.
2. Set the "SIMULATE" switch to the appropriate position according to what is being replaced by the test set:
 - Set to the "LINE" position if you are displacing the line and testing directly into the PBX or CO equipment.
 - Set to the "EQUIP" position if you are connecting to the transmission facility.
3. Set the "24/48 Volt" switch to voltage selection required on the E&M and SB leads.
4. Connect the E&M and SB/SG leads to the bantam connectors on the left side of the unit.
5. **AM5XT Only:** Connect the T,R/T1,R1 leads directly to the AM5XT. Use the bantam jack in the upper right hand corner of the front panel or the T and R screw terminals on the rear panel.

SIMULATE SWITCH POSITION

LINE

EQUIP (CO or PBX)

E&M TYPE

I

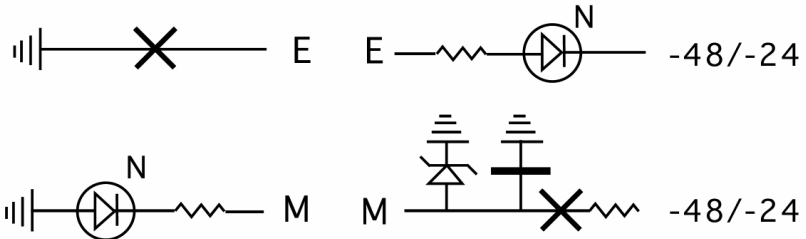

II

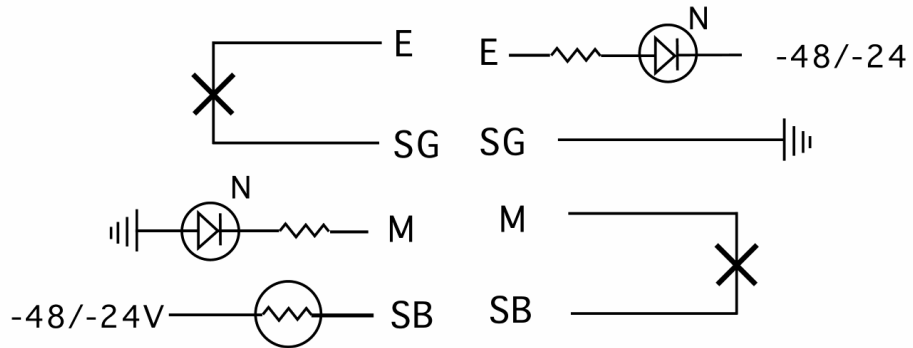

III

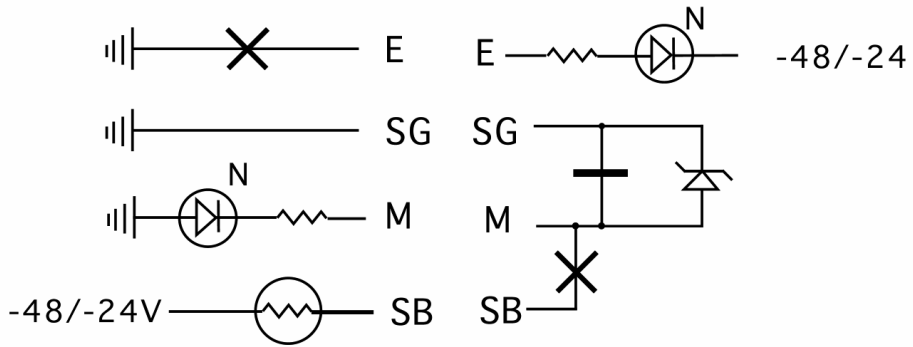

X = N.O. Contact — = N.C. Contact

Table 2-1. The "TYPE" and "SIMULATE" Switches for E&M Circuits

2.2 To Receive a Call

To set up the unit to receive a call from the other end:

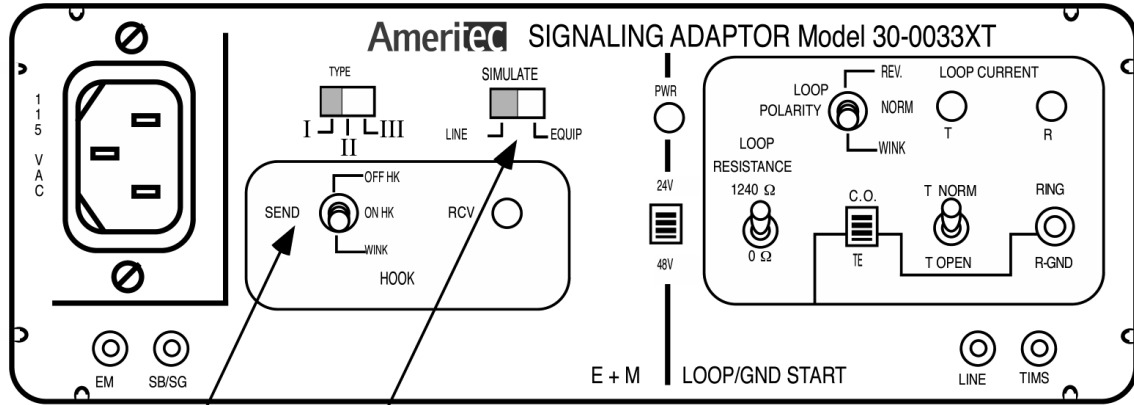

1, 3, 4 2

1. Position the "SEND" switch to "ON HK".
2. Watch for the "RCV" LED to light when an incoming call is received.
3. Press the "SEND" switch to its momentary "WINK" position and release. This will send a wink to the other end. The wink will be a typical duration of 250ms and will continue for the length of time the switch is held in the "WINK" position.
 - With the T,R/T1,R1 leads connected to the AM5XT, you should hear DTMF or MF digits being received from the other end.
 - Send additional winks for multiple-record dialing sequences if required by the circuit under test. When the other end is finished dialing:
4. Position the "SEND" switch to the "OFF HK" position to simulate answer. The line is now ready for testing.

2.3 To Originate a Call

To set up the unit to originate a call to the other end:

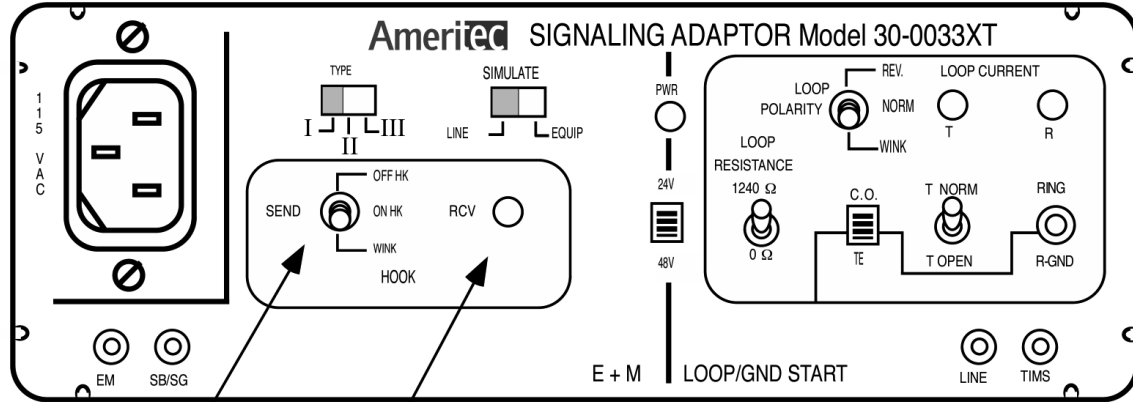

1

2, 4

1. Position the "SEND" switch to "OFF HK".
2. Watch for the "RCV" LED to wink.
3. **AM5XT Only:** Use the AM5XT's Dialing Mode Enable Key to select either DTMF or MF dialing.
 - Send the required digits using the AM5XT's Function Select Keys ([1] through [0], [*] and [#]).
4. If the called number provides "answer supervision", the "RCV" LED lights permanently when the line is ready for testing .

3. GROUND START APPLICATIONS

3.1 Set Appropriate Operating Conditions

Connect the Model 30-0033(XT) to a 115VAC power source. Verify that the "PWR" LED in the center of the unit is lit. Connect the line under test and the AM5XT to the unit. Note that the right half of the unit is used for operation on loop start, ground start and DID circuits.

See Figure 3-1 for a schematic representation of the use of the "POLARITY" and the "T-NORM"/"T-OPEN" switches when the 30-0033(XT) is functioning with the "CO"/"TE" switch in the "CO" position. The functioning of the "R-GND" pushbutton with the "CO"/"TE" switch in the "TE" position is also illustrated.

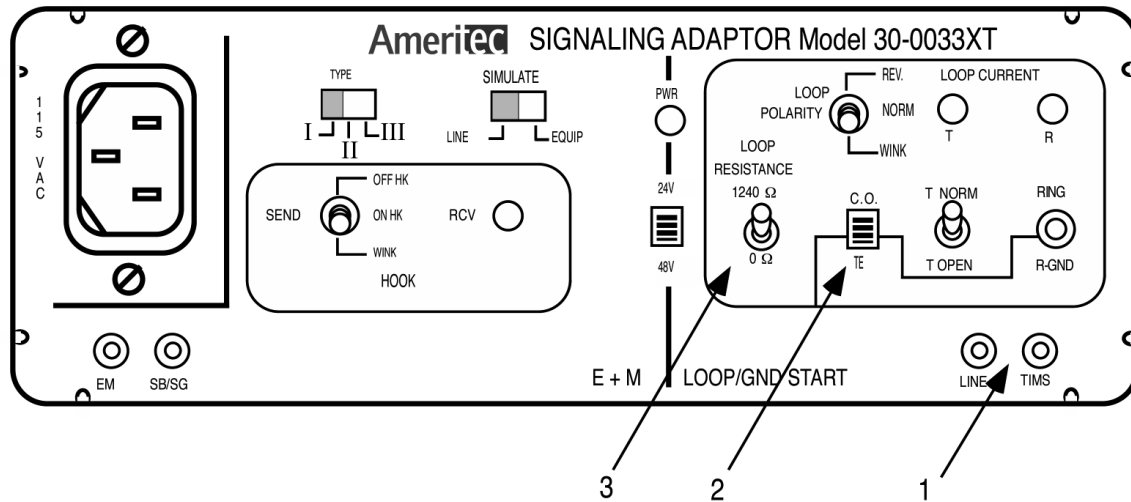

1. Connect the line under test to the "LINE" bantam connector and the AM5XT to the "TMS" bantam connector.
2. Set the "CO/TE" switch to the appropriate position:
 - Set to the "CO" position if you are simulating the CO equipment.
 - Set to the "TE" position if you are simulating a PBX.

WARNING: Before connecting the Signaling Adaptor to a circuit which has battery voltage applied already (wet circuit), be sure that the C.O./TE switch is set to the TE position. Damage to Signaling Adaptor may result if the unit is set to C.O. position when it is connected to a wet circuit.

3. Set the "1240/0 ohm" switch to the appropriate loop selection (30-0033XT ONLY).

Note: When the "CO/TE" switch is in the "CO" position, the "POLARITY" switch, "T-NORM"/"T-OPEN" switch, "RING" switch, 1240/0 ohm switch and the "T" and "R" LEDs are active. When in the "TE" position, only the "R-GND" pushbutton is active.

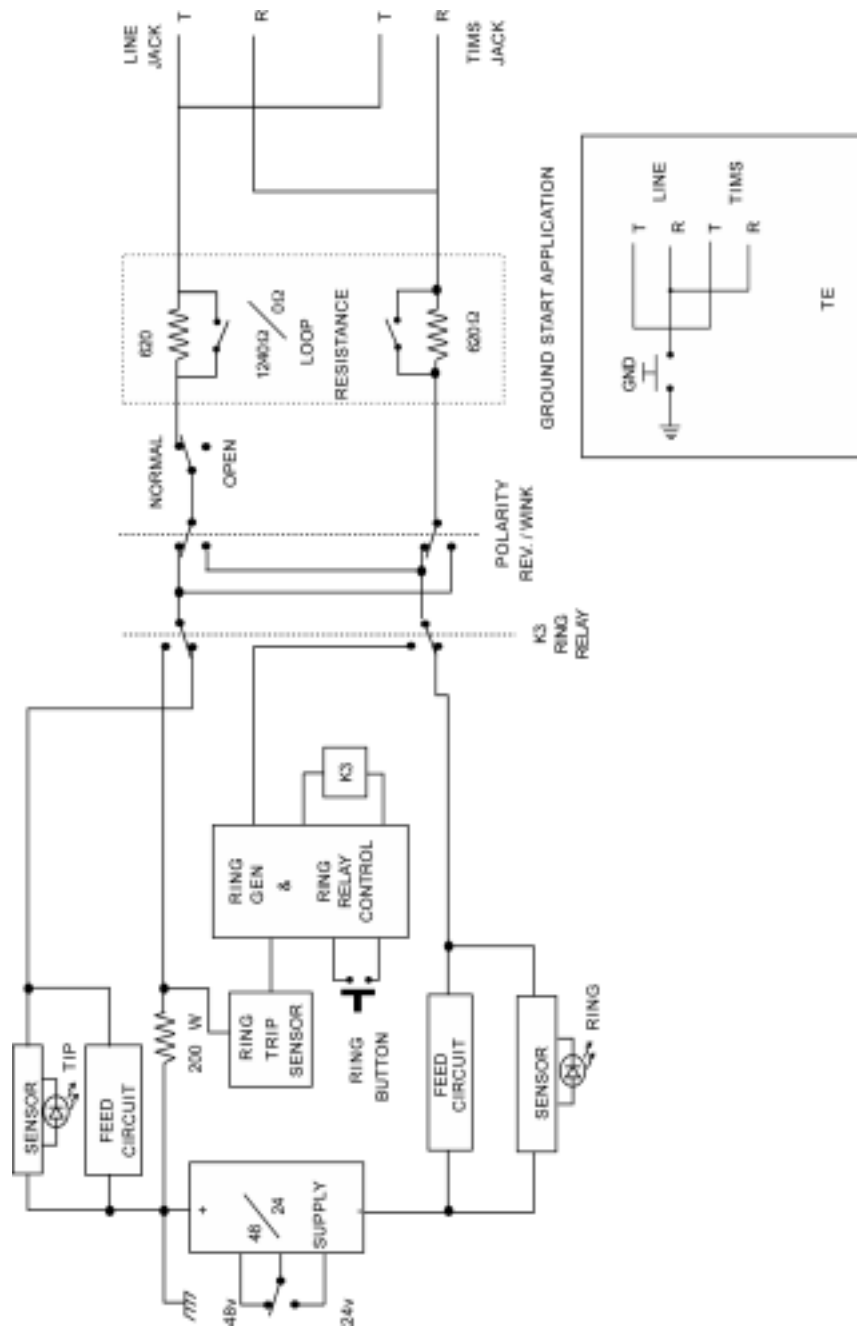

3.2 To Simulate a PBX

Be sure that the "CO/TE" switch is in the "TE" position. Notice that the settings of the "POLARITY" switch and the "T-NORM"/"T-OPEN" switch have no effect in the "TE" mode.

WARNING: Before connecting the Signaling Adaptor to a circuit which has battery voltage applied already (wet circuit), be sure that the C.O./TE switch is set to the TE position. Damage to Signaling Adaptor may result if the unit is set to C.O. position when it is connected to a wet circuit.

Perform the following steps:

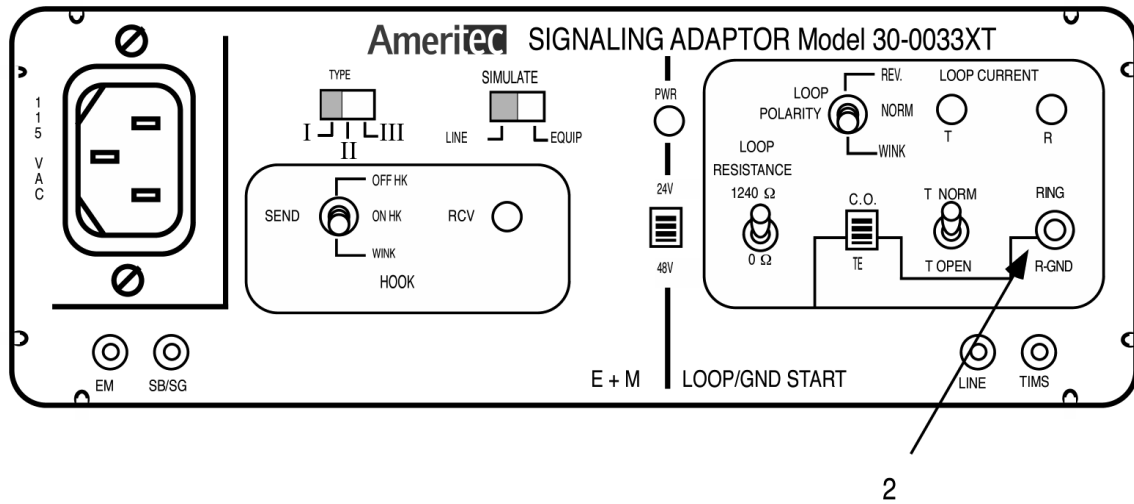

3.3 To Originate a call to the CO.

1. **AM5XT Only:** Set the AM5XT off-hook.
2. Push the "R-GND" button until dial tone is heard at the AM5XT.
3. **AM5XT Only:** Use the AM5XT's Dialing Mode Enable Key to select either DTMF or MF dialing. Send the required digits using the AM5XT's Function Select Keys ([1] through [0], [*] and [#]). When the CO answers, the line is ready for testing.

3.4 To Terminate a call from the CO:

1. **AM5XT Only:** When ringing is heard at the AM5XT, go offhook at the AM5XT. The line is now ready for testing.

3.5 To Simulate a CO

Be sure that the "CO/TE" switch is in the "CO" position.

WARNING: Before connecting the Signaling Adaptor to a circuit which has battery voltage applied already (wet circuit), be sure that the C.O./TE switch is set to the TE position. Damage to Signaling Adaptor may result if the unit is set to C.O. position when it is connected to a wet circuit.

Perform the following steps:

4. LOOP START APPLICATIONS

4.1 Set Appropriate Operating Conditions

- Connect the Model 30-0033(XT) to a 115VAC power source.
- Verify that the "PWR" LED in the center of the unit is lit.
- Connect the line under test and the AM5XT to the unit.

Note: the right half of the unit is used for operation on Loop Start, Ground Start and DID circuits.

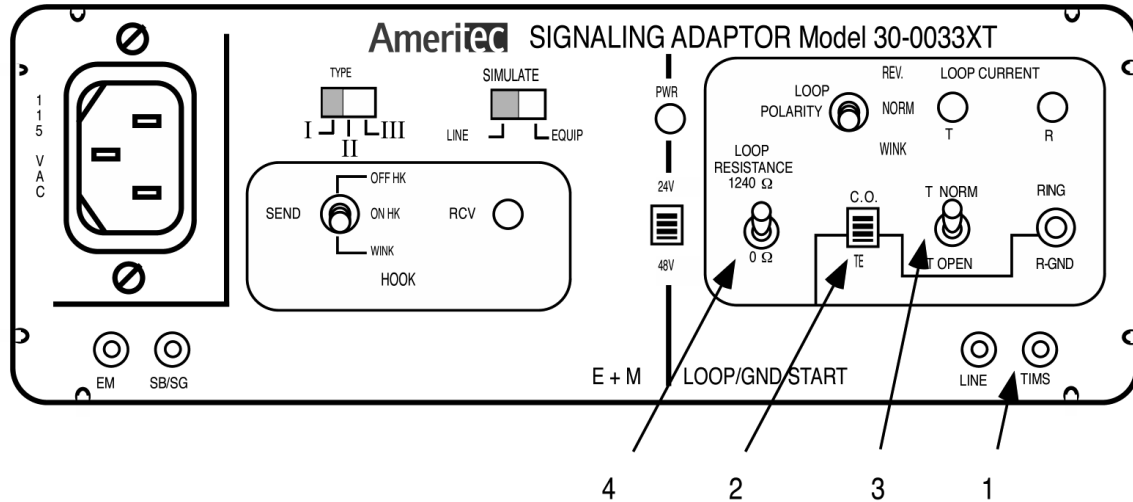

1. Connect the line under test to the "LINE" bantam connector and the AM5XT to the "TIMS" bantam connector.
2. Set the "CO/TE" switch to the appropriate position:
 - Set to the "CO" position if you are simulating the CO equipment.
 - Set to the "TE" position if you are simulating a PBX.

WARNING: Before connecting the Signaling Adaptor to a circuit which has battery voltage applied already (wet circuit), be sure that the C.O./TE switch is set to the TE position. Damage to Signaling Adaptor may result if the unit is set to C.O. position when it is connected to a wet circuit.

3. Set the "T-NORM"/"T-OPEN" switch to the "T-NORM" position for loop start applications.
4. Set the Loop Resistance to the appropriate resistance (XT ONLY).

Note: The panel silk-screening indicates that when the "CO/TE" switch is in the "CO" position, the "POLARITY" switch, "T-NORM"/"T-OPEN" switch, "RING" switch and Loop Resistance and the "TIP" and "RING" LEDs are active. In the "TE" position, only the "R-GND" pushbutton is enabled but is not used in loop start applications.

4.2 To Simulate a PBX

When simulating a PBX for Loop Start applications, the 30-0033(XT) Adaptor is not actually needed since the AM5XT is capable of seizing a loop line by itself. However, the adaptor may be

used for this purpose. Be sure that the "CO/TE" switch is in the "TE" position when testing in this manner.

4.3 To Simulate a CO

Be sure that the "CO/TE" switch is in the "CO" position.

WARNING: Before connecting the Signaling Adaptor to a circuit which has battery voltage applied already (wet circuit), be sure that the C.O./TE switch is set to the TE position. Damage to Signaling Adaptor may result if the unit is set to C.O. position when it is connected to a wet circuit.

Perform the following steps:

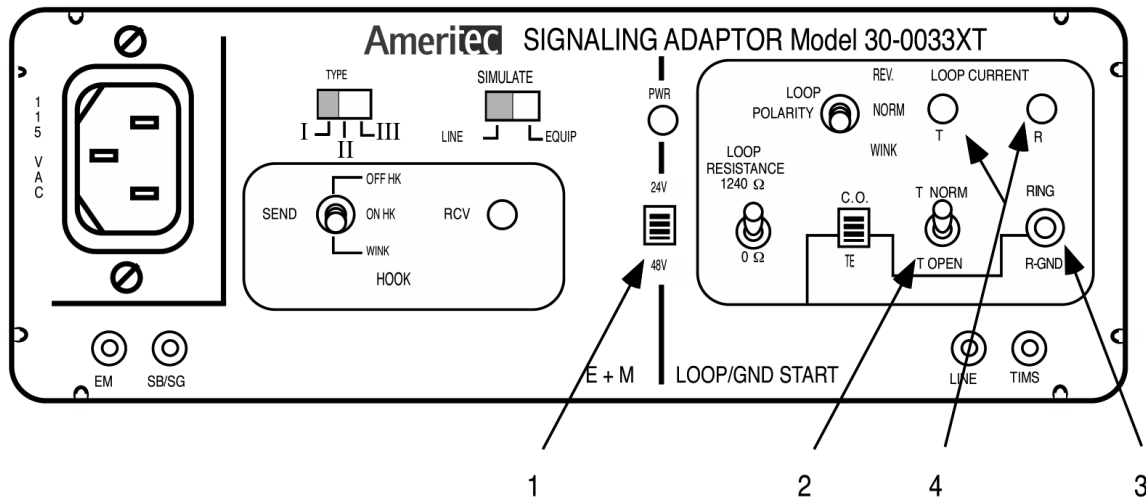

1. Set the "24/48 Volt" switch to the proper position.
2. Ensure that the "T-NORM/T-OPEN" switch is in the "T-NORM" position to apply the selected voltage to the line.
3. Set the Loop Resistance switch to the proper position (XT ONLY).

4.3.1 To Terminate a call from the PBX or Phone:

4. Watch for the "TIP" and "RING" LEDs to light to indicate that the far end has gone offhook.
5. **AM5XT Only:** Leave the AM5XT onhook and terminated. The line is ready for testing.

4.4 To Originate a call towards the PBX or Telephone (30-0033XT Only):

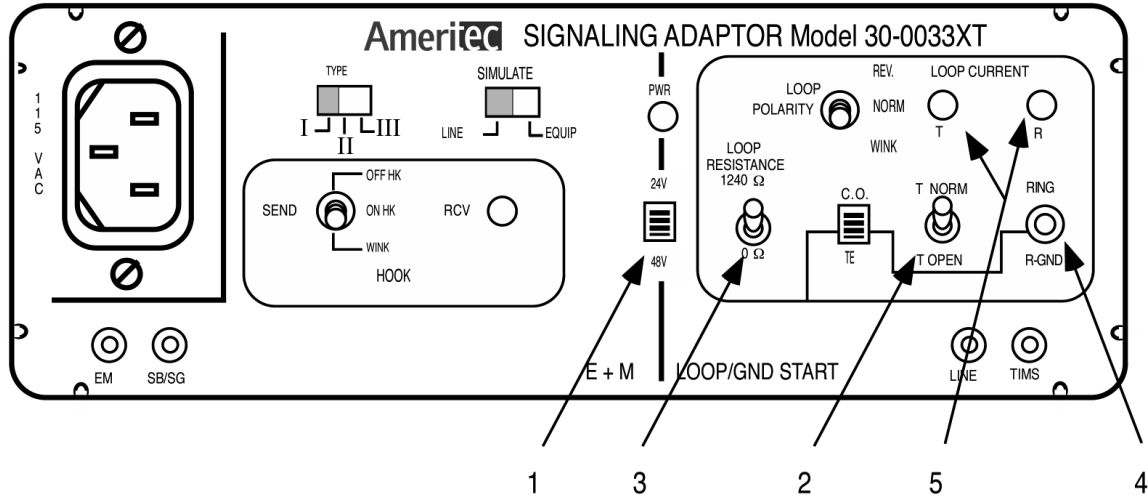

1. Set the "24/48 Volt" switch to 48 Volt.
2. Ensure that the "T-NORM/T-OPEN" switch is in the "T-NORM" position to apply the Selected voltage to the line.
3. Set the Loop Resistance switch to the desired position.
4. Press the "RING" switch to apply ringing to the PBX or telephone.
5. Watch for the "TIP" and "RING" LEDs to light to indicate that the far end has gone offhook.
6. **AM5XT Only:** Leave the AM5XT onhook and terminated. The line is ready for testing.

5. DIRECT INWARD DIAL (DID) APPLICATIONS

5.1 Set Appropriate Operating Conditions

Connect the Model 30-0033(XT) to a 115VAC power source. Verify that the "PWR" LED in the center of the unit is lit. When simulating a PBX for DID applications, set the "CO/TE" switch in the "CO" position. Perform the following steps:

WARNING: Before connecting the Signaling Adaptor to a circuit which has battery voltage applied already (wet circuit), be sure that the C.O./TE switch is set to the TE position. Damage to Signaling Adaptor may result if the unit is set to C.O. position when it is connected to a wet circuit.

5.2 To Simulate a PBX DID Operation:

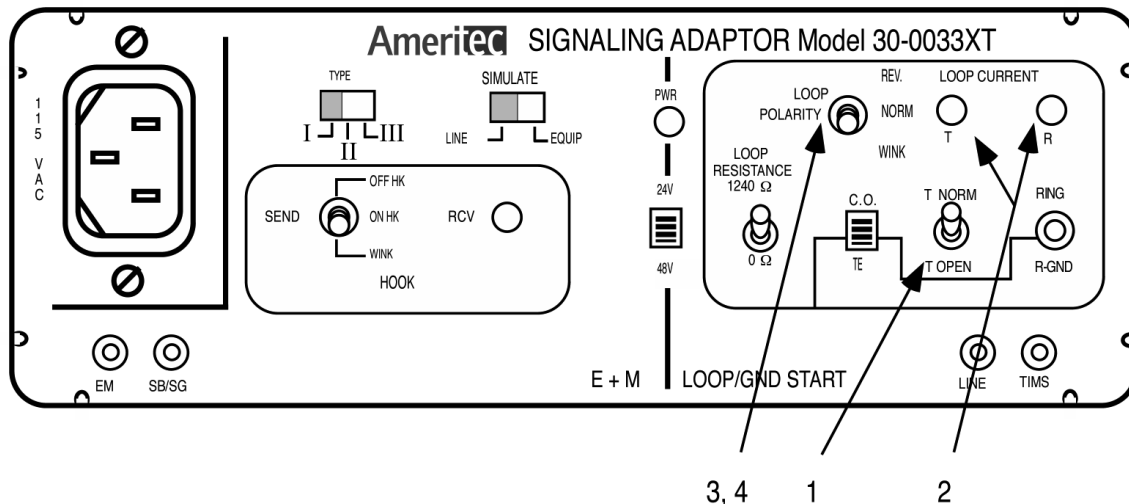

1. Set the "T-NORM/T-OPEN" switch to the "T-NORM" position.
2. Watch for the "TIP" and "RING" LEDs to blink to indicate the CO has seized the line.
3. Press the "POLARITY" switch to its momentary "WINK" position and release. This will send a wink to the other end. The wink will be a typical duration of 250ms and will continue for the length of time the switch is held in the "WINK" position.
 - With the Tip and Ring leads connected to the AM5XT, you should hear DTMF or MF digits being received from the other end.
 - Dialing may also be DP. In that case, the Tip and Ring LEDs will blink and "clicks" will be heard at the AM5XT.
 - When the other end has finished dialing, continue with step 4.
4. Position the "Polarity" switch to "REV" position to indicate answer. The line is now ready for testing.

5.3 To Simulate a CO DID Operation:

Be sure that the "CO/TE" switch is in the "TE" position. (When in the "TE" position, only the "R-GND" pushbutton is enabled.)

WARNING: Before connecting the Signaling Adaptor to a circuit which has battery voltage applied already (wet circuit), be sure that the C.O./TE switch is set to the TE position. Damage to Signaling Adaptor may result if the unit is set to C.O. position when it is connected to a wet circuit.

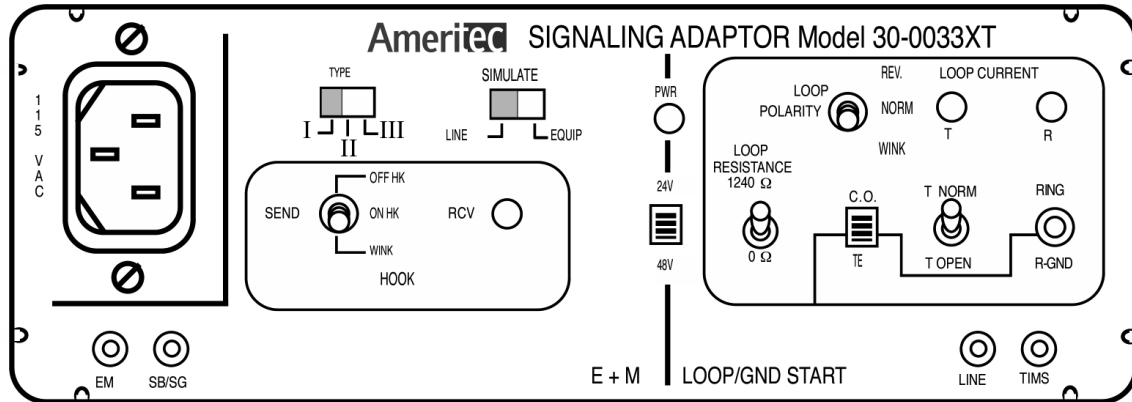

Note: Front panel for reference only; no indications during the following procedure.

AM5XT Only:

1. Go offhook at the AM5XT.
2. Listen for the "thump" caused by a wink of polarity reversal from the PBX.
3. Use the AM5XT's Dialing Mode Enable Key to select either DTMF or MF dialing. Send the required digits using the AM5XT's Function Select Keys ([1] through [0], [*] and [#]). The line is now ready for testing.

6. WARRANTY AND SERVICE POLICY

Ameritec Corporation warrants that its electronic instrument products are manufactured to the highest commercial standards and are free from any defects in material or workmanship. For a period of one (1) year from shipment, Ameritec will repair without charge to the original purchaser any unit which upon inspection by Ameritec proves to be defective.

This warranty is the sole warranty offered by Ameritec and is in lieu of all other obligations or liabilities, including claims of consequential damage; however, an EXTENDED WARRANTY PLAN may be purchased. For information contact an Ameritec Sales Representative.

6.1 Service Policy

Ameritec products are designed with plug-in printed circuit boards and modular assemblies. Once a problem is localized, service is accomplished by PC board (or module) replacement.

6.2 Calibration Policy

All Ameritec products are manufactured to commercial standards and are calibrated with equipment traceable to NIST (National Institute of Standards and Technology). With the exception of component failures or abuse, Ameritec instruments are designed to maintain compliance with their published specifications throughout their service life.

While periodic calibration verification is normally not required, in critical applications it is recommended that verification be accomplished annually.

Calibration verification is most efficiently accomplished by return of the equipment to the Ameritec factory where specialized test equipment is used. Field calibration verification is not supported by Ameritec.

6.3 Return of Unit

In the event of a malfunction call or write to the Ameritec factory and obtain a return authorization number. Return the unit to Ameritec freight prepaid with a note in-warranty repair) or a Purchase Order for the repair (out-of-warranty repair) listing the following information:

Return authorization number from Ameritec.

Return shipment address of purchaser.

Name and telephone number of person at purchaser's location familiar with the problem.

Brief description of problem (include any printouts that may have a bearing on the problem, if possible).

Terms of payment for repair costs (out-of-warranty unit).

The unit will be repaired and returned freight-prepaid for units in warranty and freight-collect for units out-of-warranty. As stated above, a Purchase Order to cover the cost of repair must accompany any out-of-warranty return of the unit to Ameritec.

Ameritec

760 Arrow Grand Circle
Covina, CA 91722 USA

TEL 626.915.5441

FAX 626.915.7181

www.ameritec.com



Ameritec is dedicated to serving the worldwide telecommunications community by providing competitively priced, state-of-the-art test equipment that is supported by the finest in marketing, engineering development and customer service.

Ameritec

760 Arrow Grand Circle
Covina, CA 91722 USA
TEL 626.915.5441
FAX 626.915.7181
www.ameritec.com